

BALL VALVES RK-PROBALL

KH 2T E, DN6 - DN16, PN63

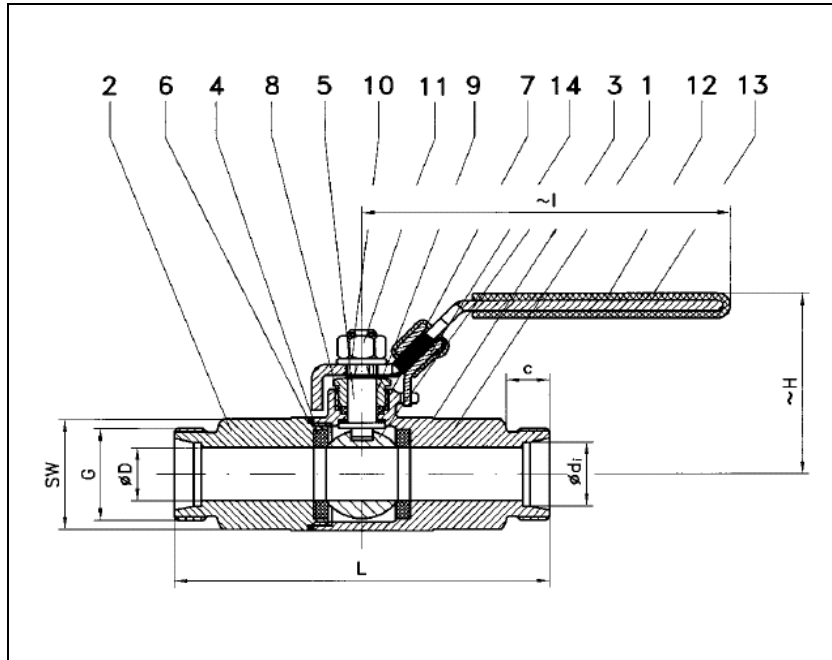

Ball valve with pipe screwing
light series acc. to DIN 3861
full bore
face to face acc. to DIN 3202 V1

Specification:

Two-piece ball valve with pipe screwing light series acc. to DIN 3861, full bore, blow-out-proof stem, body material stainless steel (1.4408), free of non-ferrous metals, seat KFG, stem KF, design acc. to EN 19, safety spring locking device is optional.

Marking: RK-Proball
Type: KH 2T E-1.4408

No.	Part	Material
1	body	1.4408
2	cap	1.4408
3	ball	1.4408
4	seat	KFG
5	stem	1.4401
6	seal	KFG
7	thrust washer	PTFE
8	stem packing	KF
9	gland nut	1.4301
10	washer	1.4301
11	nut	1.4301
12	lever	1.4301
13	insulation cover	Vinyl
14	spring locking device*	1.4301

* special type

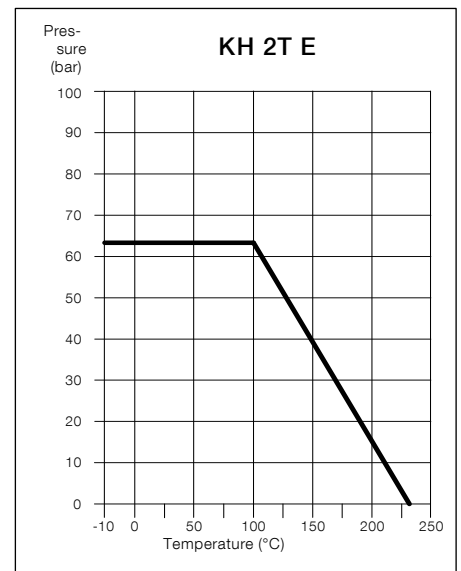

Ordering example:
KH 2T E, DN6, PN 63, 1.4408,
safety spring locking device

Dimensions

DN mm	dimensions (mm)			L	H	I	C	G	SW **	Kv-value m³/h	weight kg
	di	D									
6	8	6.0		76	50	102	10	M14x1.5	22	3	0.2
8	10	8.0		76	50	102	11	M16x1.5	22	5	0.2
10	12	10.0		80	50	102	11	M18x1.5	22	6	0.3
12	15	12.0		96	50	102	12	M22x1.5	24	7	0.3
16	18	15.0		105	52	102	12	M26x1.5	27	9	0.3

** width across in mm